

HXL75WV

Vacuum / Pressure Pump

Masport have been manufacturing vacuum/pressure pumps for over 100 years, so you can be sure of engineering excellence.

The Masport range of HXL pumps are specifically designed and engineered to meet the needs of hard working pumpers around the world.

To produce our precision pumps, we only use the finest quality components and materials to ensure the durability of your vacuum pump.

Every pump is factory tested before shipping and is backed up by a one year warranty against all manufacturing defects.

With Masport on board you have an efficient and reliable pump backed by the best service and support that has made Masport the #1 choice for pumpers worldwide.

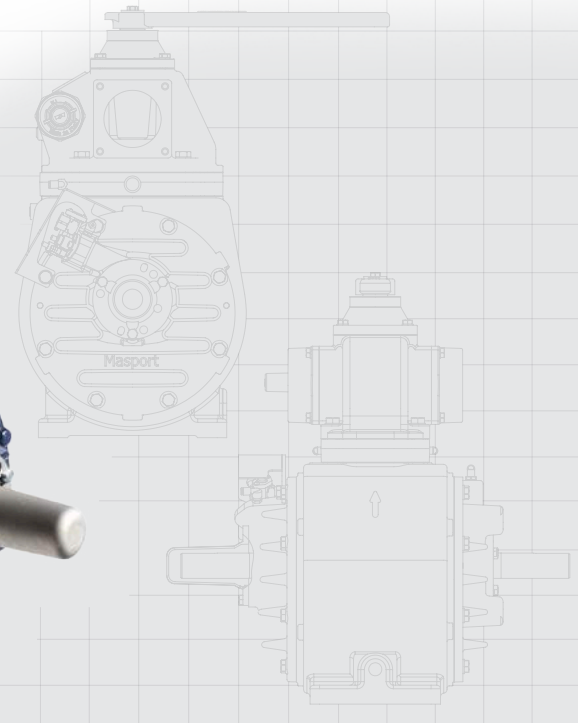
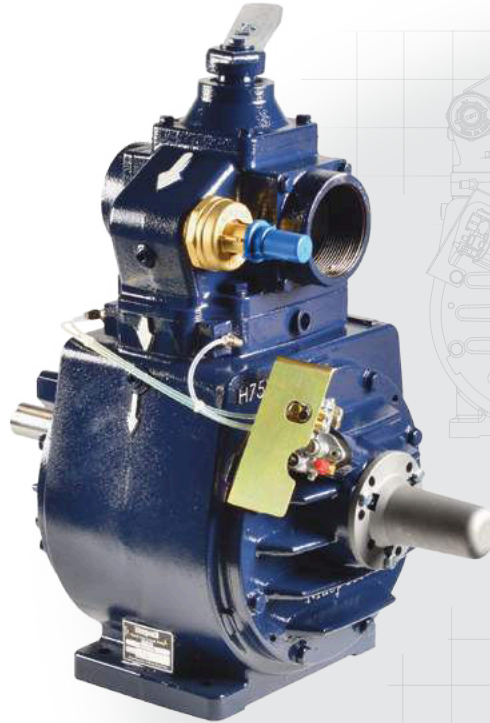

Masport quality and performance

- ▶ **Achieve minimum 27" Hg** (Intermittent)
- ▶ **Liquid stabilized design**– provides reliable operation under extreme hot or cold weather conditions, and allows for higher continuous vacuum operations
- ▶ **Precise machining and assembly**
- ▶ **Heavy duty bearings**
- ▶ **Viton oil seals** for longer service life
- ▶ **Kevlar vanes** are heat stabilized and machined with exacting tolerances for superior ruggedness and durability
- ▶ **Mechanical oil pump** with automatic oiling that delivers the right amount of oil at all working levels – no adjustment required
- ▶ **Durable translucent high temperature oil lines** – allows visible flow of oil to the pump
- ▶ **Integral mounting bosses** guarantee precise alignment for hydraulic drive or gearbox mount applications
- ▶ **End Thrust Protection** prevents rotor to-endcover contact created by direct PTO drive or misaligned belt driven systems
- ▶ **3" NPT bolt-on valve flanges** for ease of installation
- ▶ **¼" NPT vane flush port**
- ▶ **Integral vacuum relief valve**
- ▶ **Double end shaft** accommodates clockwise or counter-clockwise drive systems
- ▶ **Integral valve** allows the pump to operate in vacuum and pressure mode and reduces plumbing and installation costs
- ▶ **O-Ring Endcovers** eliminates air or oil leakages
- ▶ **Easy to service**
- ▶ **One year performance warranty**



230 CFM

Free Air Displacement



HXL75WV

Vacuum / Pressure Pump

Performance Data – Vacuum

PUMP R.P.M	DISPLACEMENT C.F.M	S.C.F.M and A.C.F.M @ VACUUM											MAXIMUM VACUUM – “Hg	
			5	10	15	18	20	22	24	25	26	27	CONTINUOUS	INTERMITTENT
1100	196	SCFM	140	110	79	61	47	36	22	15	9	3	25	27
		ACFM	168	165	158	152	142	134	111	92	66	30		
1250	230	SCFM	162	127	92	71	55	43	26	18	10	3.5	25	27
		ACFM	195	190	184	177	164	160	129	108	77	35		

Performance Data – Pressure

PUMP R.P.M	DISPLACEMENT C.F.M	S.C.F.M @ P.S.I.G							MAXIMUM PRESSURE – P.S.I.G	
		5	10	15	18	20	25	30	CONTINUOUS	INTERMITTENT
1100	196	168	160	152	143	134	127	119	20	35
1250	230	193	184	175	165	134	146	136	20	35

Horsepower Required @ “Hg

PUMP R.P.M	VACUUM “Hg				
	5	10	15	20	27
1100	6.9	8.1	8.3	9.3	10.5
1250	7.8	9.2	9.7	10.8	12.3

Horsepower Required @ P.S.I.G

PUMP R.P.M	P.S.I.G				
	5	10	15	20	25
1100	9.4	12.1	15.0	18.8	21.0
1250	11.0	14.2	17.7	20.9	24.6

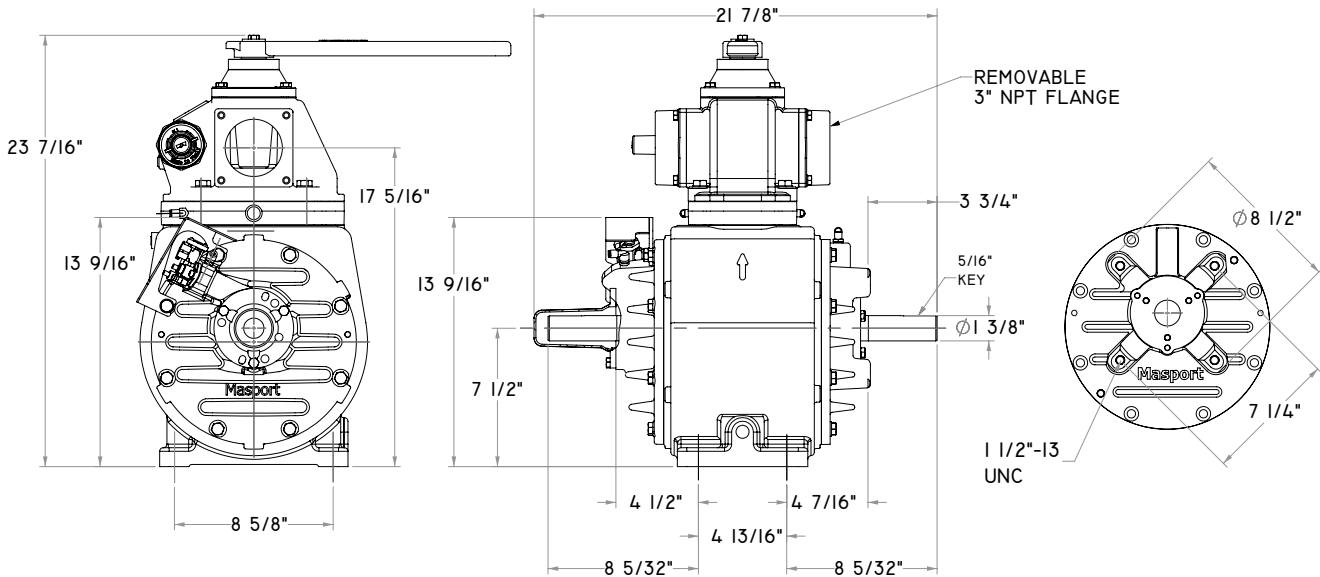

Superior reliability and performance features built into every Masport pump



Integral mounting bosses guarantee alignment with gearbox and hydraulic mount



Automatic adjustment free mechanical oil pump



Oil Reservoir and Flushing Kits available with either plastic or steel reservoirs



Heat stabilized Kevlar vanes machined to exacting tolerances

